

Features	
Series:	T
Type:	60
Code:	07.625.145.11
Description:	T601010ENC12C12
Customer's code:	-
Colour:	Black

Last drawing	
Index: -	Date: -

Application	
-	

Driveline data	
X	1 3/8" Z6 DIN 9611
Y	1 3/8" Z6 DIN 9611
E	850-33.46"
I	865-34.06"
P	780-30.71"

Overlap		
	Steel tubes	Guard
Max.	817-32.17"	760-29.92"
Min.	290-11.42"	233-9.17"

Greasing point	
1)	-
2)	-

The dimensioning is cross to cross

Cross and tubes	
	54x4
	45x4

End fittings		Max. torque
Tractor	Cod: C12	-
Implement	Cod: C12	-

Notes:
 CERTIFIED

Warning !
 Sections of driveline marked are not shielded and must be shielded by an interactive guarding system.
 COMER spa declines responsibility if proper guards are not provided or maintained.

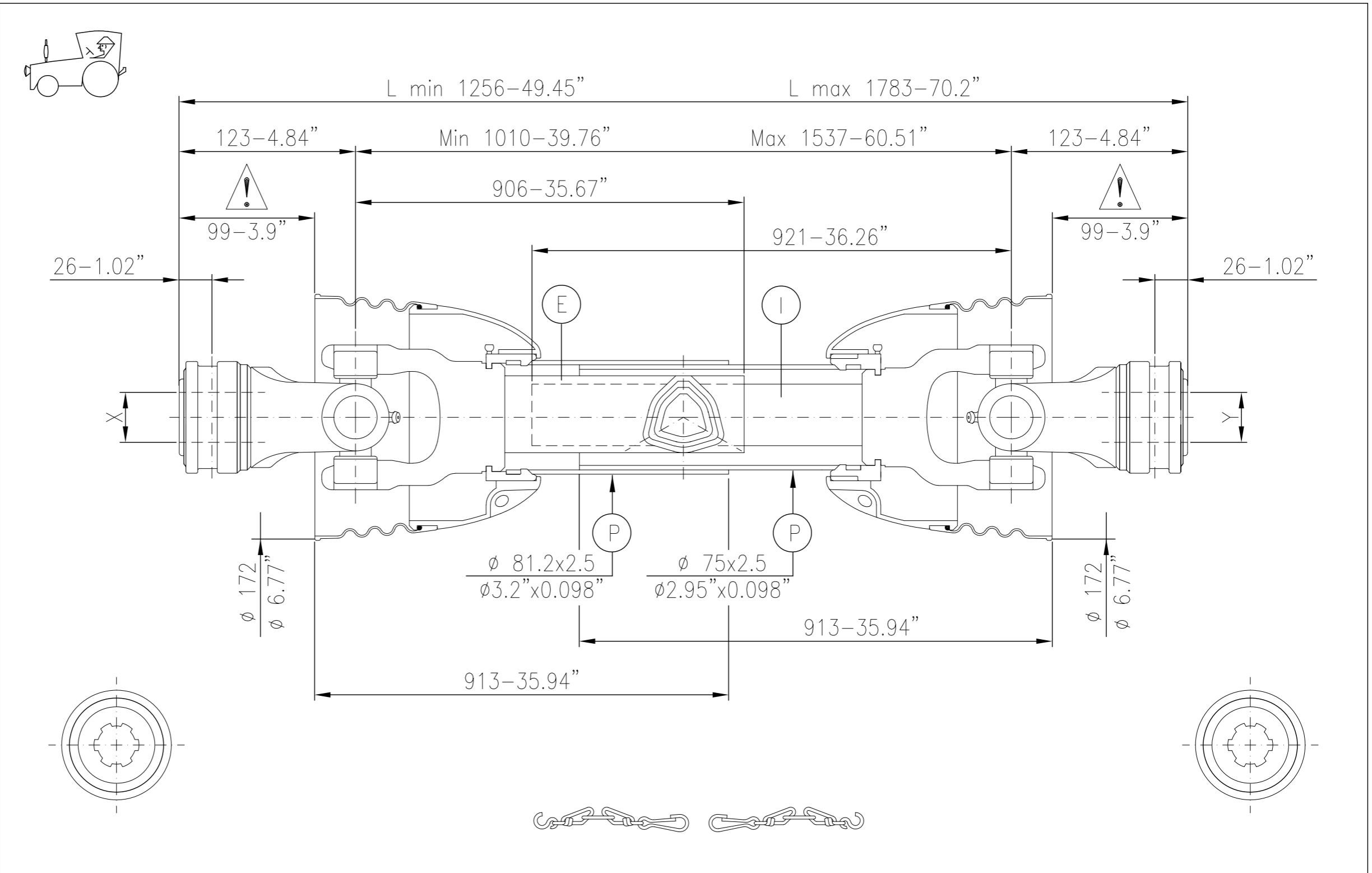

Data 540 r.p.m.			
KW	CV	Nm.	in.lb.
47	64	830	7350

Data 1000 r.p.m.			
KW	CV	Nm.	in.lb.
74	100	710	6259

1100 min.⁻¹
 r.p.m. max.

Data for only critical velocity	
540 r.p.m.	1000 r.p.m.
Max. -	Max. -
L max. -	L max. -
Checked:	Signed by: A.S.

Customer: - - -
 Date: 31-10-17

Continuous operation data and conditions, working angle 5°, average life 1000 hours